

TCF 0504 U 500 02 A Engineering Specification

1. Scope

TCF0504U series is a thin film common mode filter designed to suppress common mode noise for high speed differential data lines, such as **USB 3.0** and **DisplayPort**.

2. Explanation of Part Number

TCF 0504 U 500 02 A □□
 (1) (2) (3) (4) (5) (6) (7)

- (1) Product Type : TCF= Thin Film Common Mode Filter
- (2) EIA Dimension Code
- (3) Speed Identification Code: : U= Ultra High Speed
- (4) Impedance(at 100MHz): 500= 50
- (5) Line Code: 02= 2 lines
- (6) Specialized Specification Code
- (7) Control code

3. Circuit Diagram & Dimension

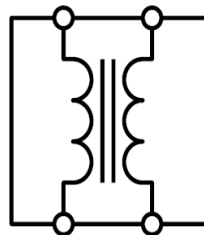
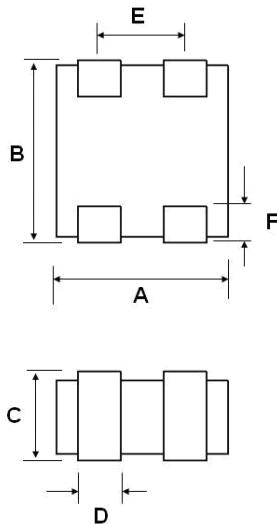

Unit: mm

Series	A	B	C	D	E	F
TCF 0504	0.95±0.1	1.25±0.2	0.6±0.15	0.25±0.15	0.5±0.1	0.2±0.15

4. Specifications

4.1. ABSOLUTE MAXIMUM RATINGS

PARAMETER	PARAMETER	RATING	UNITS
Rated Voltage	V_{DC}	10	V
Rated Current	I_{DC}	100	mA
Lead Soldering Temperature	T_{SOL}	260 (10 sec.)	$^{\circ}C$

4.2. ELECTRICAL CHARACTERISTICS

PARAMETER	MIN	TYP	MAX	UNITS
Common Mode Impedance (at 100 MHz)	37	50	63	Ω
DC Resistance			1.5	Ω
Insulation Resistance	10			$M\Omega$

4.3. TYPICAL CHARACTERISTICS

Impedance vs Frequency Characteristics*

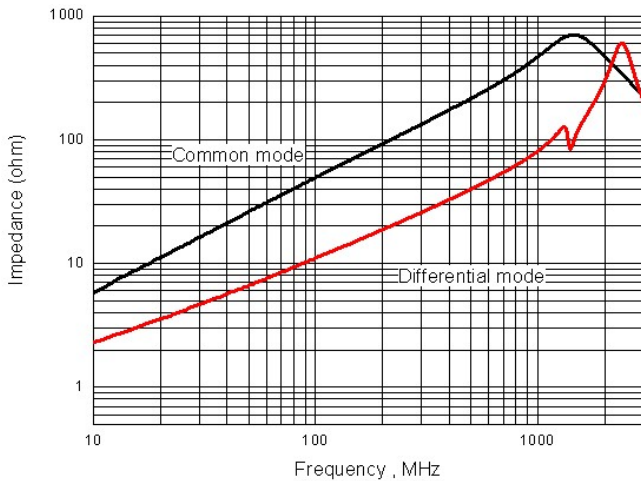

Insertion Loss vs Frequency Characteristics**

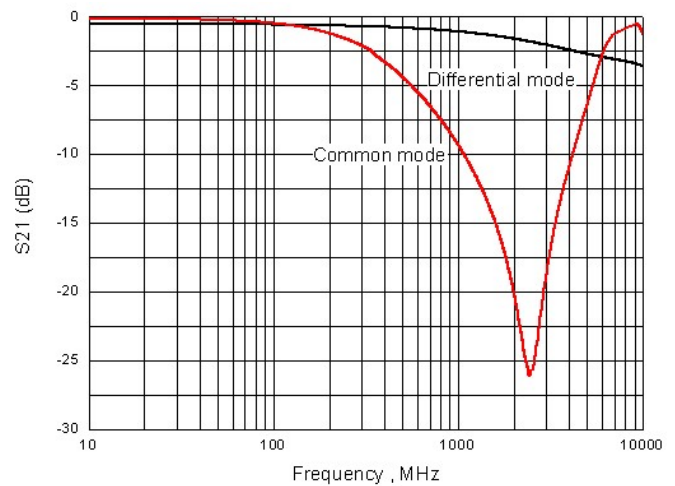

*Test Instrument: Agilent E4991A Impedance/Material Analyzer

**Test Instrument: Agilent E5071C ENA Series Network Analyzer

5.LAND LAYOUT

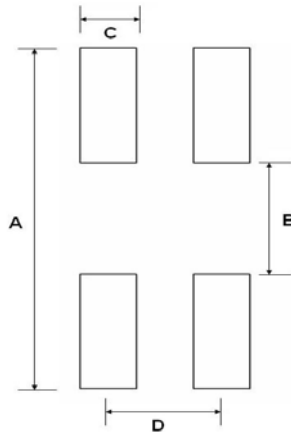

	mm
A	1.6
B	0.4
C	0.25
D	0.5

6.Recommendable reflow soldering

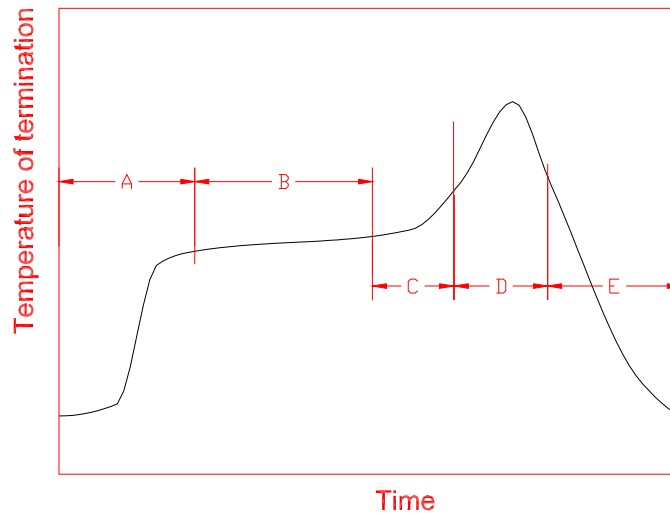

A	1 st rising temperature	The normal to Preheating temperature	30s to 60s
B	Preheating	140°C to 160°C	60s to 120s
C	2 nd rising temperature	Preheating to 200°C	20s to 40s
D	Main heating	if 220°C if 230°C if 240°C if 250°C if 260°C	50s~60s 40s~50s 30s~40s 20s~40s 20s~40s
E	Regular cooling	200°C to 100°C	1°C/s ~ 4°C/s

- According to J-STD-020C

7. Tape and reel specifications

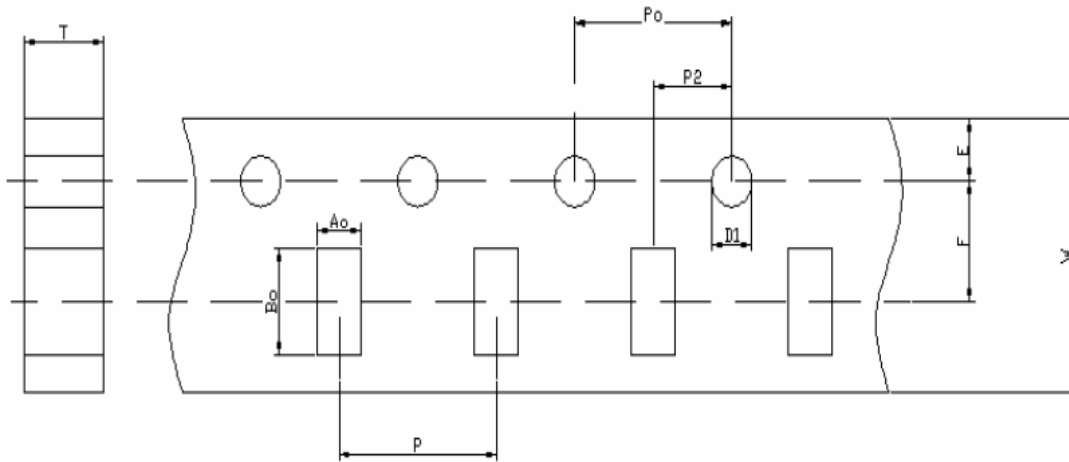

W	7.90-8.30
P	4.00±0.10
E	1.75±0.10
F	3.50±0.05
D1	1.55±0.05
Po	4.00±0.10
P2	2.00±0.05
Ao	1.15±0.10
Bo	1.55±0.10
T	0.75±0.10

Unit: mm

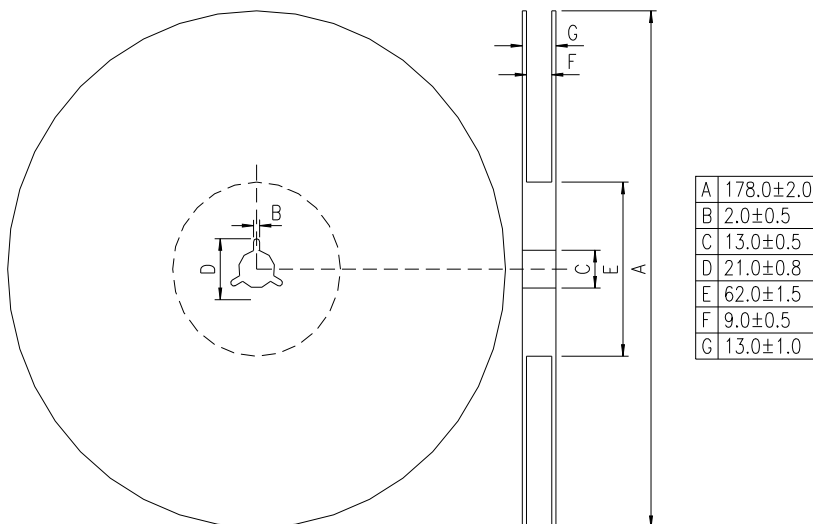

A	178.0±2.0
B	2.0±0.5
C	13.0±0.5
D	21.0±0.8
E	62.0±1.5
F	9.0±0.5
G	13.0±1.0

*Standard quantity : 5000pcs/Reel